



Dairy Farm Products

Barry Brown & Sons have been supplying and installing high quality new and used stainless steel tanks, chillers and associated equipment since 1970.



**Quality Farm Milk
Storage Tanks**



**Milk Cooling &
Chiller Systems**

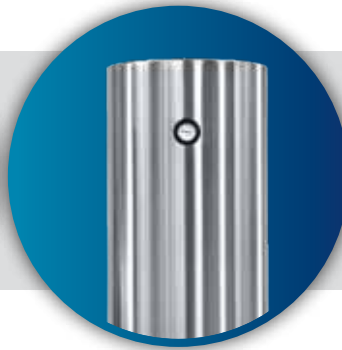

**Heat Recovery
'Free' Hot Water**



**Tank Wash
Systems**

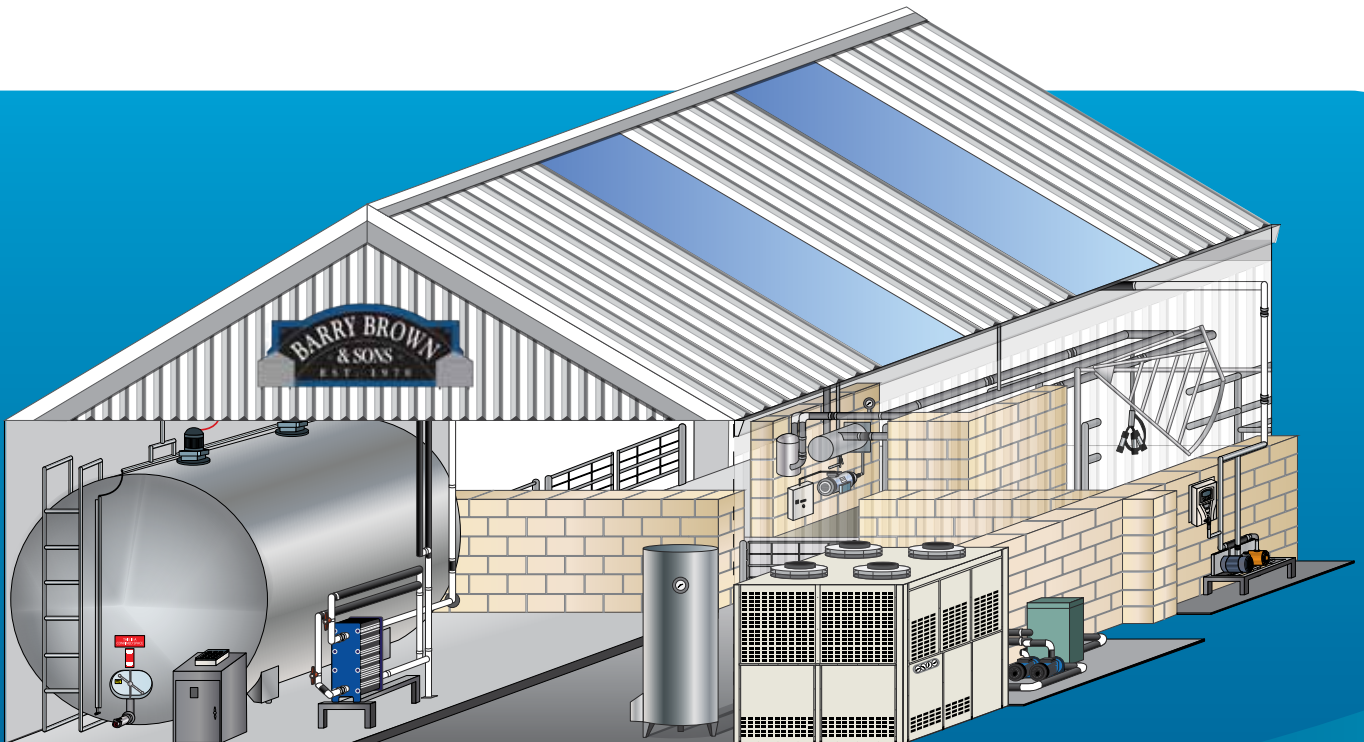

Telephone: 03 5941 6111 | **Fax:** 03 5941 5888

Web: www.barrybrown.com.au **Email:** info@barrybrown.com.au

Address: 12 Drovers Place Pakenham, VIC 3810

Quality Farm Milk Storage Tanks

We can supply and install the highest quality stainless steel Milk Storage Tanks in sizes and capacities to suit your dairy.

Barry Brown & Sons Tanks are...

- Energy efficient
- Designed for faster cooling through chilled water jacket
- Compliant with dairy company cooling performance tests
- Constructed for long life
- Installed with our advanced wash system for highly effective cleaning
- Low maintenance
- 100% stainless steel construction
- Supplied with service back-up second to none

Vertical and Horizontal tanks available in standard sizes from 6,300 litres to 41,000 litres.

Standard Specifications*:

- All tanks are manufactured from type 304-2B Stainless Steel
- Includes standard man way
- Bottom Fill to reduce foaming through non return valve
- 75mm diameter outlet, complete with 75mm butterfly valve - reducing to 50mm
- Heavy duty agitator motor - .37kW 36 rpm. Single or Three Phase.
- Fixed stainless steel ladder with non-slip tread.
- Each Farm Milk Storage Tank meets stringent Government Weights and Measures Standards
- Tanks are completely insulated with high density Polyurethane. Other options available
- All tanks can have an alcove fitted for outside installations
- Horizontal tanks can be installed through a wall with only 1500mm of tank actually in milk room.

*Complies with Australian standard 1187 - 1996. Approval Number 8/89 & 8/90.



Tank Sizes

Horizontal Farm Milk Tank Sizes

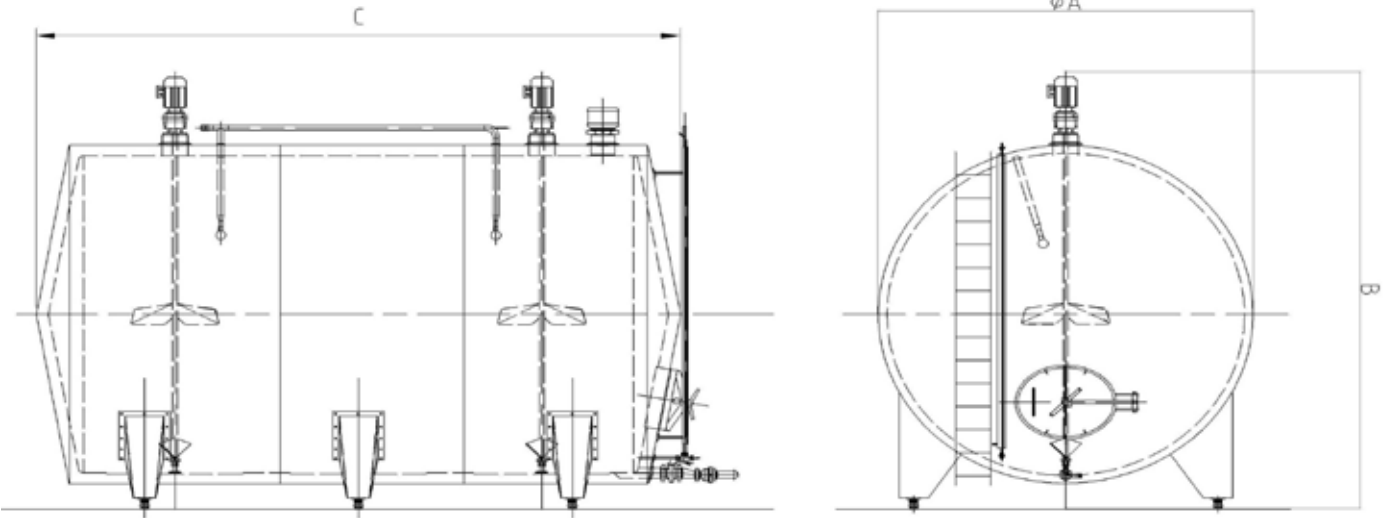

1950mm Diameter Horizontal Silos					
SIZE IN LITRES	DIMENSIONS			AGI	CIP
	A	B	C		
6 300	1 950	2 600	3 220	1	2
8 500	1 950	2 600	4 120	2	2
10 000	1 950	2 600	4 820	2	2
12 000	1 950	2 600	5 720	2	2
12 500	1 950	2 600	6 320	2	3

2500mm Diameter Horizontal Silos					
SIZE IN LITRES	DIMENSIONS			AGI	CIP
	A	B	C		
10 300	2 500	3 140	3 020	1	2
12 500	2 500	3 140	3 620	1	2
15 000	2 500	3 140	4 220	2	2
17 500	2 500	3 140	4 820	2	2
20 000	2 500	3 140	5 420	2	2
22 500	2 500	3 140	6 020	3	3
25 000	2 500	3 140	6 620	3	3
30 000	2 500	3 140	7 820	3	3

2800mm Diameter Horizontal Silos					
SIZE IN LITRES	DIMENSIONS			AGI	CIP
	A	B	C		
18 000	2 800	3 440	3 900	1	2
25 500	2 800	3 440	5 300	2	2
29 500	2 800	3 440	6 050	2	2
33 000	2 800	3 440	6 700	3	3
37 000	2 800	3 440	7 450	3	3
40 500	2 800	3 440	8 150	3	3

Note: Please subtract 260mm from dimension B for 90° motor

Sizes shown are approximate and subject to change without notice.

Vertical Farm Milk Tank Sizes

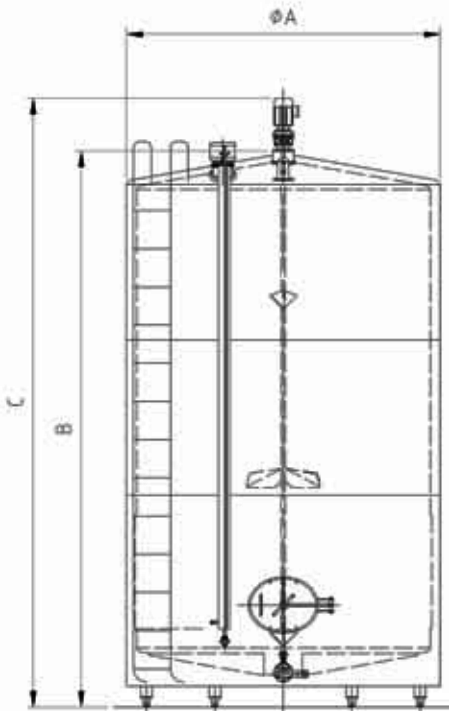

2500mm Diameter Vertical Silos		
SIZE IN LITRES	DIMENSIONS	
	A	B
6 300	2 500	2 720
9 000	2 500	3 320
10 000	2 500	3 620
12 500	2 500	4 220
15 000	2 500	4 820
18 500	2 500	5 720

3050mm Diameter Vertical Silos		
SIZE IN LITRES	DIMENSIONS	
	A	B
18 000	3 050	4 230
20 000	3 050	4 530
23 500	3 050	5 130
25 500	3 050	5 430
27 500	3 050	5 730
29 500	3 050	6 030
31 500	3 050	6 330
35 000	3 050	6 930
41 000	3 050	7 830

Note: Please subtract 260mm from dimension B for 90° motor

“Did you know milk vats cooled via chilled water operate at very low pressure (MAX. 35 PSI) which minimises the risk of jacket failure and in the unlikely event of a water leak the cost to refill the system with glycol is only \$500 compared to a typical direct expansion vat costing thousands to refill with refrigerant gas.”



Air Cooled Water Chiller Systems

Cooling milk faster and more efficiently improves milk quality and increase farm profits.

Over the past 20 years we have developed and perfected a fast and efficient system for cooling milk on dairy farms using Glycol/Water Chillers.

With chillers available in all sizes and to suit single or three phase power we can supply a cooling system specifically designed for your dairy and milk storage requirements.

Chiller Features:

- Stainless Steel Heat Exchangers
- Scroll & Semi Hermetic Screw Compressor Models Available
- Inbuilt Heat Reclaim
- Galvanised and Polyester Powder Coated Base, Frame and Unit Panels
- Carel Controllers
- Zeil abeg Condensor Fans

Chiller Benefits:

- Hi-efficiency cooling
- Peak economy at all loads
- Lower installation costs
- Energy saving technology
- Lower maintenance costs
- Inbuilt safety protection features



Chiller System & Milk Cooling Explained

Did you know the heat transfer efficiency of a chilled water vat is higher than refrigerant gas (direct expansion)!

In fact, even the factory you supply your milk to is using chillers to cool milk, not to mention that most other food processors (wineries, fruit juice, etc) all use chillers to cool their product!

A chiller can be fitted to almost any vat and is a common solution for direct expansion vats which develop a gas leak to avoid further costly gas refills & repairs.



How it works:

A mix of food grade propylene glycol and chilled water is pumped through a second (or dual bank) plate heat exchanger to cool the milk to approx. 7°C and through the tank jacket to cool the milk to 4°C. The food grade glycol is added to the water to lower the freeze point so the cooling system can operate at approx. minus 2°C for rapid cooling.



Heat Recovery - 'Free Hot Water'



Our heat recovery system exploits the otherwise wasted heat generated by a refrigeration unit's compressor to heat water within the heat recovery vessel. The water will typically reach 55°C to 65°C with the heat provided by the refrigerant gas and can be further boosted by the electric element inside the heat recovery device.

The hot water produced by the heat recovery unit can be used for cleaning milk vats and milking equipment or to supply pre heated water to existing hot water services already cleaning this equipment.

Advantages

- Significantly reduces cost of water heating
- Suitable for mains pressure
- Increases efficiency of refrigeration systems
- Constant hot water provision
- Maintenance - free – No Moving Parts
- Corrosion protection and highly efficient insulation
- Simple electric heating element and thermometer replacement

Construction and Main Parts of the Heat Recovery Unit

- AISI 304 stainless steel outer shell
- AISI 316 stainless steel inner vessel
- High density environment friendly polyurethane foam insulation
- Two independent circuits for connecting separate refrigeration units
- 6500W electric heating element to boost the water temperature if required
- Thermostat to regulate the desired water temperature
- Thermometer mounted on the outer shell for accurate monitoring of water temperature
- An 8-10bar safety valve is installed on the water inlet to protect the system

Operation Principle

The heat recovery tank is connected to the refrigeration system between the compressor and the condenser. The (hot) discharge refrigerant gas passes through the heat recovery tank jacket which heats the water inside the tank. The refrigerant gas coming out of the tank is cooler due to the heat exchanged with the water inside prior to entering the condenser. This has a positive effect on the condensers performance and on the efficiency of the whole refrigeration system.

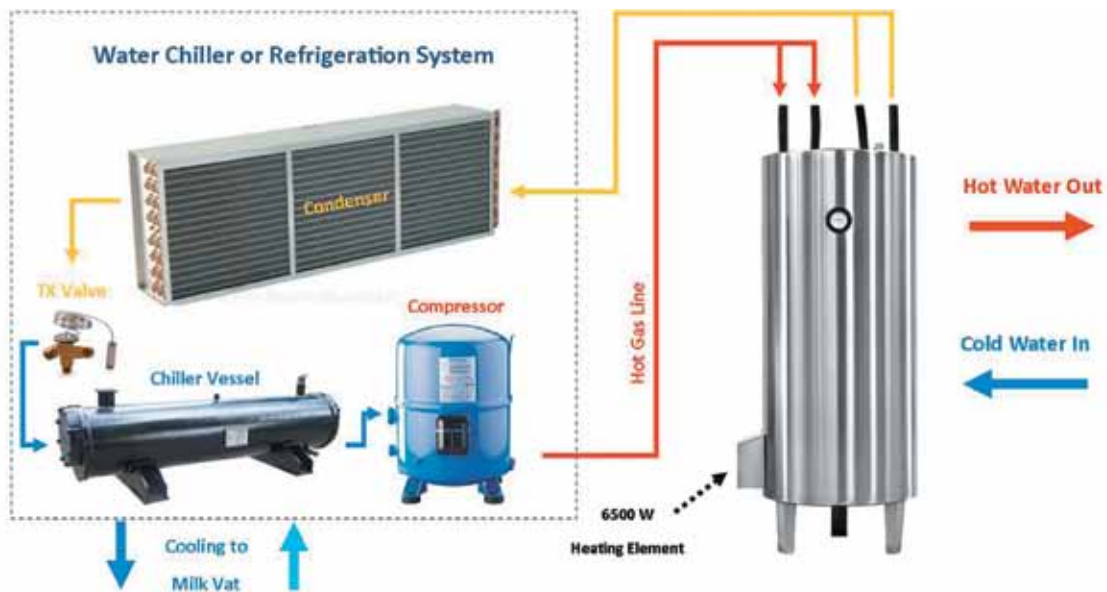

Sizes & Capacities

Capacity (lt)	Diameter of the inner shell (mm)	Height of the inner shell (mm)	Diameter of the outer shell (mm)	Height of the outer shell (mm)	Total height (with base) (mm)	Weight (kg)
400	660	1240	760	1500	1670	135
500	690	1240	790	1500	1670	149
600	800	1240	900	1500	1670	166
800	920	1240	1020	1500	1670	194
1000	1020	1240	1120	1500	1670	222



Variable Speed Milk Pump System



Conventional on/off milk pumps transfer milk from the dairy to the milk vat via the plate cooler in bursts which often exceed the cooling capacity of the plate cooler and refrigeration system. The milk then enters the vat at a higher temperature and the refrigeration system has to run for longer periods of time to cool the milk inside the vat.

A variable speed milk pump system from Barry Brown & Sons will match the speed of the milk pump to the flow of milk coming from the milking plant. This will reduce the flow rate of milk through the plate cooler, allowing it to transfer more heat and send colder milk to the vat, resulting in refrigeration equipment operating for less time which reduces both running and maintenance costs. Tests of the system in the field have seen **refrigeration running time reduced by over 20%**.

Features:

- Available to suit 3 phase or 2 phase 480v power supply (milk pump must be 3 phase)
- Weatherproof enclosure
- Milk probe with stainless steel gland
- Pre wired and programmed, ready for electrician to install

Variable Speed Vacuum Pump System



Traditional vacuum pumps run at a constant speed regardless of the demand for air in the dairy. Research has found this represent approximately 80% of energy used by the milking equipment components, with opportunity for this to be reduced and significant energy savings to be made.

Barry Brown & Sons can supply a variable speed vacuum pump system which will match the speed of the pump to the demand for air in the dairy. Like our milk pump system it will reduce both running and maintenance costs. Depending on the type of pump the system is installed on (oil vane or blower) the expected **energy saving is between 40-80%**.

Features:

- Available to suit 3 phase or 2 phase 480v power supply (vacuum pump must be 3 phase)
- Suits both oil vane and blower type pumps
- IP54 weatherproof rating
- Pressure transducer
- Pre wired and programmed, ready for electrician to install



Plate Heat Exchangers



Plate coolers form a vital part of any well designed and efficient dairy milk pre-cooling system. Utilising (bore, tank, river, dam or channel) water as your first stage of low cost pre-cooling, and combined with our state of the art glycol/water chillers for the second stage we can design a system that will put milk into your vat at around 4°C.

Having evolved over the years to keep up with the change in farms, dairy platforms and milk pumps, which have led to the development of larger plate coolers designed for higher milk flow rates. Their efficiency comes from the amount of surface area which the milk is in contact with as it passes through the plate cooler, so it's critical to get the size of the plate cooler right for the job.

Barry Brown & Sons supply plate heat exchangers from Sondex Australia, a leader in the design & manufacture of plate coolers to suit the dairy industry. With our combined experience in milk cooling we're able to ensure the right plate cooler is supplied.



Plate cooler hints...

- A plate cooler should be sized to suit the milk pump, if you've upgraded the milk pump and not the plate cooler then chances are it's undersized.
- Adding more plates to existing plate coolers is not always beneficial, taller plate coolers are better suited to the higher milk flow of modern pumps and provide longer contact time for heat transfer.
- A dirty plate cooler can be as high as 50% inefficient so annual cleaning is recommended.
- Cooling milk quickly through a plate cooler reduces bacteria and leads to better quality milk.

A Sondex plate cooler from Barry Brown & Sons will help improve milk quality and cut the cost of milk cooling!

Tank Wash Systems



Improved vat cleaning technology = better milk quality & increased farm efficiency!

Our tank wash system is compatible with any make of tank and is far more cost effective than most OEM systems

Barry Brown & Sons fully automatic recirculating wash system offers:

- Up to 40% reduced water usage
- Longer contact time for chemicals to perform
- Reduced OH&S risks by minimizing chemical handling & eliminating manual tank cleaning
- Optional integrated cooling system control with GPRS capability for remote access to wash/cooling functions & programming

Features

- Integrated cooling controls
- Fully programmable controller to suit your requirements
- Free standing stainless steel enclosure to suit any tank
- Automatic chemical dosing pumps
- Quality brass solenoids
- Full flow 2" dump valve
- Stainless steel head wash pump



Spare Parts

Replace that leaking seal or worn out gearbox before it's too late!

Barry Brown and Sons full range of spare parts includes:

- Door Seals
- O-Rings and O-Ring Kits
- Butterfly Valves (complete or seals only)
- Sight Glass Valves
- Sight Glass Tube
- Dump Valves
- Chemical Dosing Pumps
- Hot & Cold Water Solenoids
- Flow Switches
- Temperature Probes
- Cooling & Wash System Controllers
- Spray Balls
- Gearboxes
- Stainless Steel Head Pumps
- Refrigeration Units (made to order)
- Glycol, Inhibitor and Cleaning Chemicals
- We also stock a range of other stainless steel fittings, unions, pipe & bends

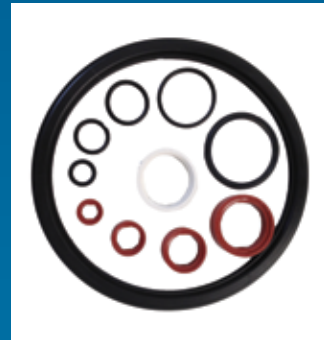

Telephone: 03 5941 6111 | **Fax:** 03 5941 5888

Web: www.barrybrown.com.au

Email: info@barrybrown.com.au

Address: 12 Drovers Place Pakenham, VIC 3810

